

1 HEAD DETAIL

SCALE: FULL

DEEP GUIDE
 ALUMINUM EXTRUSION
 MAGNETIC ONE LITE • MOL

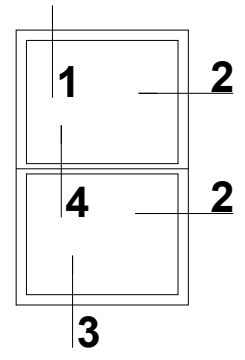

MACHINE BOLT AND LOCKNUT
 OPTIONAL SOLID BLOCKING
 REQUIRED IN PANELS OVER
 50" OR EXCEEDING 35 lbs.

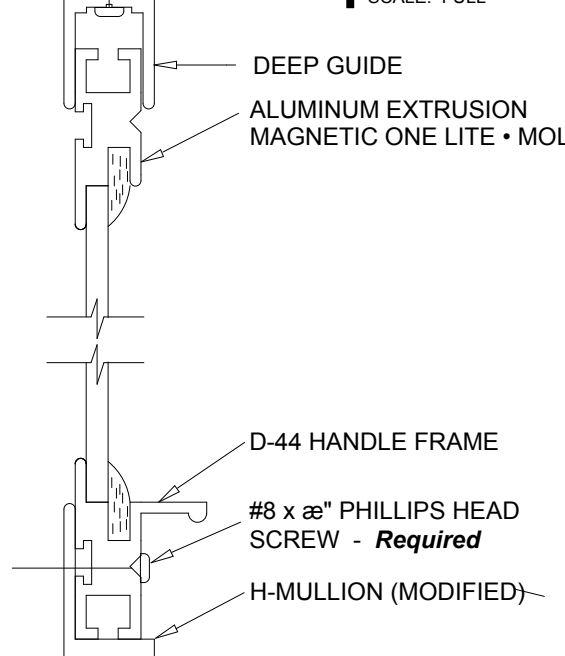

4 MEETING RAIL DETAIL

SCALE: FULL

D-44 HANDLE FRAME
 #8 x 3/8" PHILLIPS HEAD
 SCREW - **Required**
 H-MULLION (MODIFIED)

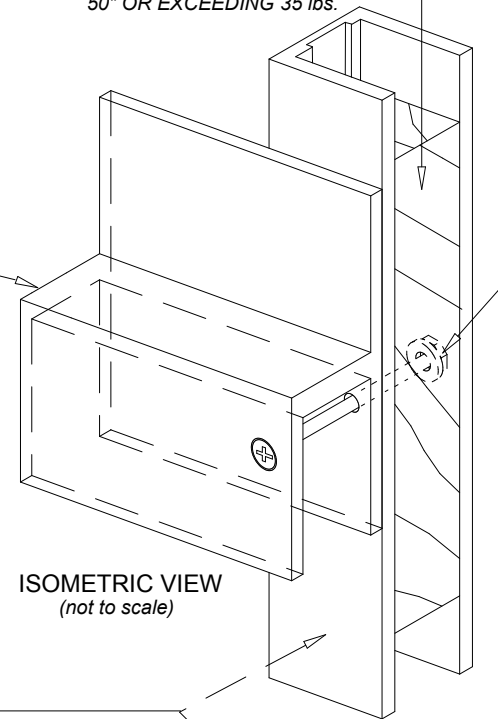

ISOMETRIC VIEW
 (not to scale)

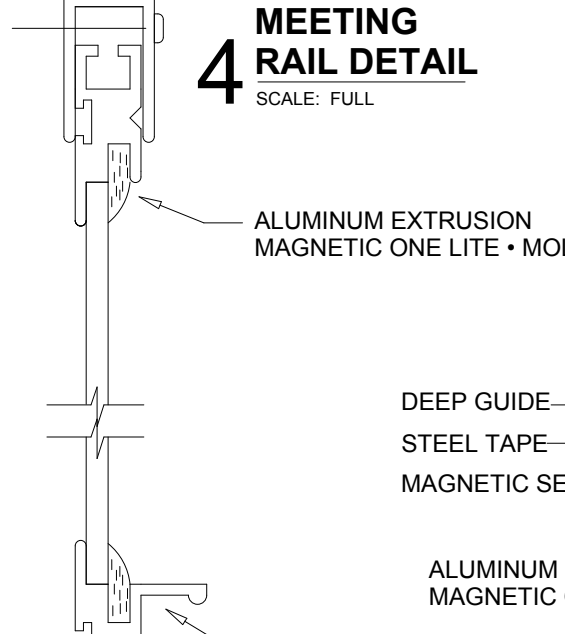

3 SILL DETAIL

SCALE: FULL

ALUMINUM EXTRUSION
 MAGNETIC ONE LITE • MOL
 D-46 HANDLE FRAME
 SILL SEAL
 WEATHERSTRIPPING

DEEP GUIDE
 STEEL TAPE
 MAGNETIC SEAL TAPE

ALUMINUM EXTRUSION
 MAGNETIC ONE LITE • MOL

2 JAMB DETAIL

SCALE: FULL

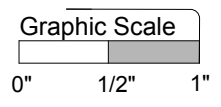

PRODUCT
 MAGNETIC ONE LITE, STACKED • MOL-ST
 PERMANENT MULLION

DWG. NO.
M-3

